

# Sample Paper 2

Class X 2022-23

Science (086)

Time: 3 Hours

Max. Marks: 80

## General Instructions:

1. This question paper consists of 39 questions in 5 sections.
2. All questions are compulsory. However, an internal choice is provided in some questions. A student is expected to attempt only one of these questions.
3. Section A consists of 20 Objective Type questions carrying 1 mark each.
4. Section B consists of 6 Very Short questions carrying 02 marks each. Answers to these questions should be in the range of 30 to 50 words.
5. Section C consists of 7 Short Answer type questions carrying 03 marks each. Answers to these questions should be in the range of 50 to 80 words.
6. Section D consists of 3 Long Answer type questions carrying 05 marks each. Answer to these questions should be in the range of 80 to 120 words.
7. Section E consists of 3 source-based/case-based units of assessment of 04 marks each with sub-parts.

## SECTION-A

Select and write one most appropriate option out of the four options given for each of the questions 1 – 20.

1. When pH strip is dipped in each bottle, the colour shown by bottle *A* and *B* will be respectively:

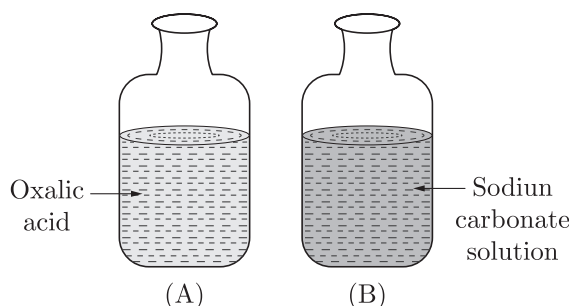

- (a) orange, blue  
(b) blue, orange  
(c) green, blue  
(d) blue, green
2. Complete the following chemical reaction with correct option:
- $$\text{Pb}(\text{NO}_3)_2 + 2\text{KI} \longrightarrow \dots\dots\dots + 2\text{KNO}_3$$
- (a)  $\text{PbI}_2$   
(b)  $\text{PbNO}_3$   
(c)  $\text{Pb}(\text{NO}_3)_2$   
(d)  $\text{PbIO}_3$

3. The given diagram represents a ..... reaction.

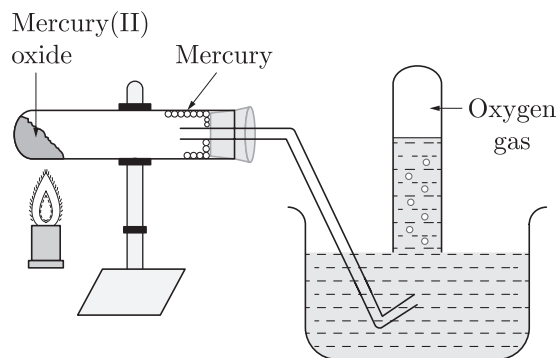

- (a) Thermal decomposition  
 (b) Displacement  
 (c) Double displacement  
 (d) Combination
4.  $\text{CuO} + \text{H}_2 \longrightarrow \text{Cu} + \text{H}_2\text{O}$   
 Which of the following pair is correct regarding to oxidation and reduction?

	Oxidation	Reduction
(a)	CuO	H <sub>2</sub>
(b)	H <sub>2</sub>	CuO
(c)	H <sub>2</sub> O	H <sub>2</sub>
(d)	H <sub>2</sub>	H <sub>2</sub> O

5. Ionic compound have high melting point due to  
 (a) Strong force of attraction between oppositely charged ions.  
 (b) Less force of attraction between oppositely charged ions.  
 (c) Strong force of attraction between similar charged ions.  
 (d) None of these
6. Which of the following substances will not give carbon dioxide on treatment with dilute acid?  
 (a) Marble  
 (b) Limestone  
 (c) Baking soda  
 (d) Lime
7. Which of the following are correct structural isomers of butane ?

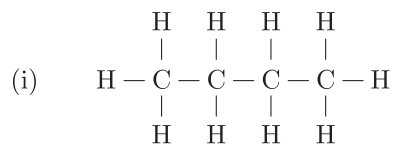

Continue on next page.....

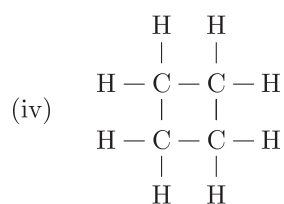
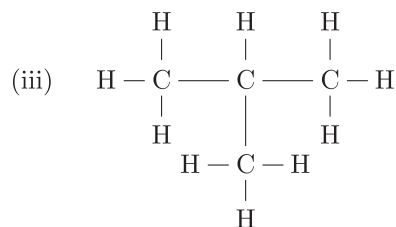
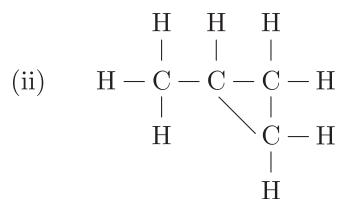

- (a) (i) and (iii)
- (b) (i) and (ii)
- (c) (ii) and (iv)
- (d) (iii) and (iv)

8. The diagram shows part of the human gas exchange system.

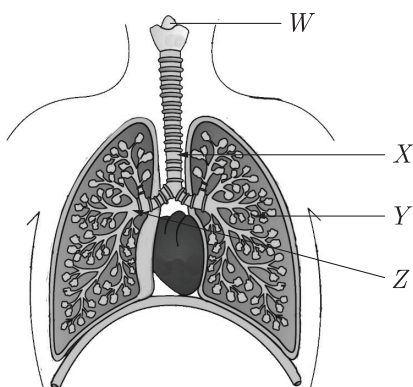

Here, W, X, Y and Z are?

	Bronchus	Bronchiole	Larynx	Trachea
(a)	W	X	Z	Y
(b)	X	Z	Y	W
(c)	Y	W	X	Z
(d)	Z	Y	W	X

9. Which process is shown by the following picture?

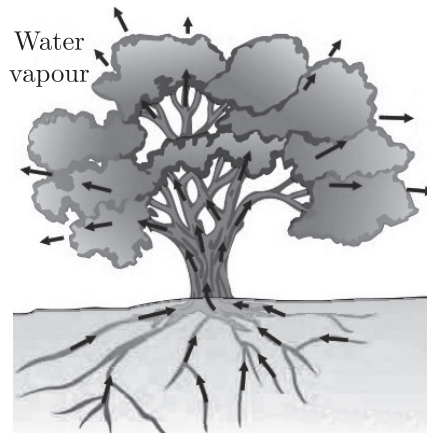

- (a) Movement of food during photosynthesis in a tree  
(b) Movement of water during transpiration in a tree  
(c) Movement of minerals during in a tree  
(d) Movement of carbon dioxide during in a tree
10. Each gamete carries only one allele. This is proposed in which law ?  
(a) law of dominance  
(b) law of segregation  
(c) law of genetics  
(d) law of assortment
11. Which of the following statements about transmission of nerve impulse is incorrect ?  
(a) Nerve impulse travels from dendritic end towards axonal end.  
(b) At the dendritic end electrical impulses bring about the release of some chemicals which generate an electrical impulse at the axonal end of another neuron.  
(c) The chemicals released from the axonal end of one neuron cross the synapse and generate a similar electrical impulse in a dendrite of another neuron.  
(d) A neuron transmits electrical impulses not only to another neuron but also to muscle and gland cells.
12. The reproductive life of a woman lasts from hacreemn to spauoemen  
(a) reproductive life a woman lasts from menarche to menopause.  
(b) reproductive life a woman lasts from menarche to menopause.  
(c) reproductive life a woman lasts from chenmare to pausemeno.  
(d) reproductive life a woman lasts from chenmare to usemenopa.
13. Electrical resistivity of a given metallic wire depends upon  
(a) its length  
(b) its thickness  
(c) its shape  
(d) nature of the material

Continue on next page.....

14. In the arrangement shown in Figure, there are two coils wound on a non-conducting cylindrical rod. Initially the key is not inserted. Then the key is inserted and later removed. Then

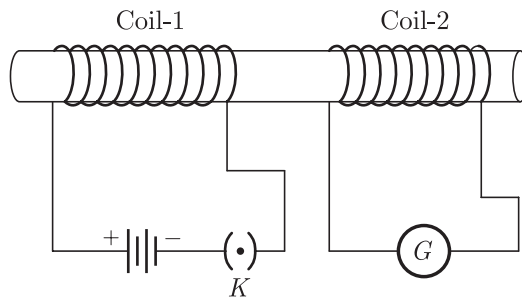

- (a) the deflection in the galvanometer remains zero throughout
  - (b) there is a momentary deflection in the galvanometer but it dies out shortly and there is no effect when the key is removed
  - (c) there are momentary galvanometer deflections that die out shortly; the deflections are in the same direction.
  - (d) there are momentary galvanometer deflection that die out shortly; the deflections are in opposite directions
15. The proper representation of series combination of cells (Figure) obtaining maximum potential is

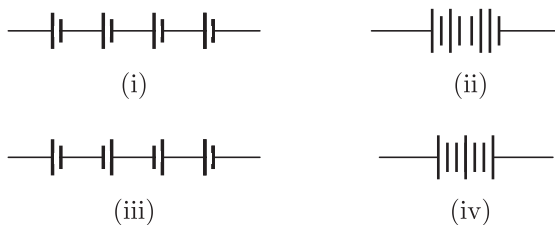

- (a) (i)
  - (b) (ii)
  - (c) (iii)
  - (d) (iv)
16. Which of the following factors affect the strength of force experience by a current carrying conductor in a uniform magnetic field?
- (a) magnetic field strength
  - (b) magnitude of current in a conductor
  - (c) length of the conductor within magnetic field
  - (d) All of above.

Question no. 17 to 20 are Assertion - Reasoning based questions.

17. **Assertion :** When iron nail is dipped in copper sulphate solution, the iron nail becomes brownish in colour and the blue colour of copper solution fade.  
**Reason :** Equation representing this change is  

$$\text{Cu} + \text{FeSO}_4 \longrightarrow \text{CuSO}_4 + \text{Fe}$$
- (a) Both Assertion and Reason are True and Reason is the correct explanation of the Assertion.
  - (b) Both Assertion and Reason are True but Reason is not the Correct explanation of the Assertion.
  - (c) Assertion is True but the Reason is False.
  - (d) Both Assertion and Reason are False.

18. **Assertion :** Chromosomes are known as hereditary vehicles.  
**Reason :** The chromosomes are capable of self-reproduction and maintaining morphological and physiological properties through successive generations.
- Both assertion (A) and reason (R) are true and reason (R) is the correct explanation of assertion (A).
  - Both assertion (A) and reason (R) are true but reason (R) is not the correct explanation of assertion (A).
  - Assertion (A) is true but reason (R) is false.
  - Assertion (A) is false but reason (R) is true.
19. **Assertion :** Ethanol is obtained during the anaerobic process of respiration.  
**Reason :** This is due to presence of oxygen and it takes place in the mitochondria.
- Both Assertion and Reason are true and Reason is the correct explanation of Assertion.
  - Both Assertion and Reason are true but Reason is not the correct explanation of Assertion.
  - Assertion is true but Reason is false.
  - Both Assertion and Reason are false.
20. **Assertion :** A current carrying conductor experiences a force in a magnetic field.  
**Reason :** The force acting on a current carrying conductor in a magnetic field is due to interaction between magnetic field produced by the current carrying conductor and external magnetic field in which the conductor is placed.
- Both assertion (A) and reason (R) are true and reason (R) is the correct explanation of assertion (A).
  - Both assertion (A) and reason (R) are true but reason (R) is not the correct explanation of assertion (A).
  - Assertion (A) is true but reason (R) is false.
  - Assertion (A) is false but reason (R) is true.

## SECTION-B

Question no. 21 to 26 are very short answer questions.

21. Pratyush took sulphur powder on a spatula and heated it. He collected the gas evolved by inverting a test tube over it as shown in Figure below :
- What will be the action of gas on
    - dry litmus paper ?
    - moist litmus paper ?

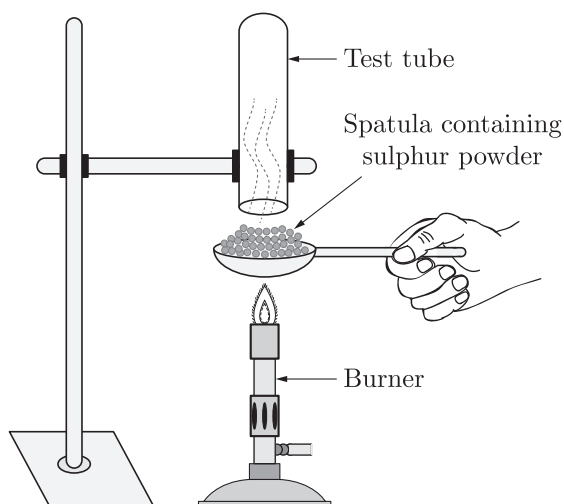

or

Write some uses of metals which are based on the properties of malleability and ductility.

22. (a) What will happen to the guard cells and stomatal pore when water flows to guard cells ?  
(b) How do plants transmit informations from cell to cell ?
23. What is the compensation point with relation to the release of  $\text{CO}_2$  by the plants ?
24. What is the cause of peptic ulcer ?
25. A person is not able to see distinctly the objects placed beyond 90 cm from him. Giving reasons to identify the defect in his eye. Determine the nature of lens used to correct this defect.

or

A star appears on the horizon. What is the true position of the star ? Explain with the help of a diagram.

26. "Energy flow in a food chain is unidirectional." Justify this statement.

## SECTION-C

Question no. 27 to 33 are short answer questions.

27. Identify the type of each of the following reactions stating reason for your answers :
- (a)  $\text{Fe}_2\text{O}_3 + 2\text{Al} \rightarrow \text{Al}_2\text{O}_3 + 2\text{Fe} + \text{heat}$   
(b)  $\text{Pb}(\text{NO}_3)_2 + 2\text{KI} \rightarrow \text{PbI}_2 + 2\text{KNO}_3$   
(c)  $\text{ZnCO}_3 \xrightarrow{\text{heat}} \text{ZnO} + \text{CO}_2$
28. Explain the following statements :
- (a) Most metal oxides are insoluble in water but some of these dissolve in water. What are these oxides and their solutions in water called ?  
(b) At ordinary temperature the surface of metals such as magnesium, aluminium, zinc etc., is covered with a thin layer. What is the composition of this layer ? State its importance.  
(c) Some alkali metals can be cut with a knife.
29. Study the picture carefully and answer the following:

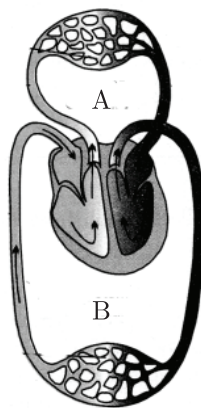

Continue on next page.....

- (a) What does diagram given below depict?
- (b) What are A and B ?
- (c) Which vessel carried deoxygenated blood to lungs and which vessel brings oxygenated blood from lungs to heart ?

**or**

How does small intestine tissues help the digestion of fats, protein and starch?

30. (a) State the relationship between focal length and radius of curvature of a spherical mirror.  
(b) Why is the refractive index of a medium always greater than one ?  
(c) A lens has  $-4\text{ D}$  power. Is the lens concave or convex ?
31. (a) Define power of a lens and write its S.I. unit.  
(b) A convex lens of power  $4\text{ D}$  is placed at a distance of  $40\text{ cm}$  from a wall. At what distance from the lens should a candle be placed so that its image is formed on the wall ?
32. A shining metal  $M$ , of burning gives a dazzling white flame and changes to a white powder  $N$ .  
(a) Identify  $M$  and  $N$ .  
(b) Represent the above reaction in the form of a balanced chemical equation.  
(c) Does  $M$  undergo oxidation or reduction in this reaction ? Justify.

**or**

Write the equations for the following metals which are obtained from their compounds by reduction process.

- (a) Metal  $X$  which is low in reactivity series.
  - (b) Metal  $Y$  which is in middle of series.
33. Larger animals kill the smaller animals in the forest, eat whatever they can, leave the rest in the forest but the forest is never found full of dead animals. What happens to the bodies of these dead animals?

## SECTION-D

Question no. 34 to 36 are Long answer questions.

34. Soaps and detergents are both types of salts. State the difference between the two. Write the mechanism of the cleaning action of soap. Why do soaps not form lather with hard water ? Mention any two problems that arise due to the use of detergents instead of soaps.

**or**

An organic compound with molecular formula  $\text{C}_2\text{H}_4\text{O}_2$ , produces brisk effervescence on addition of sodium carbonate bicarbonate.

- (a) Identify the organic compound
  - (b) Name the gas evolved.
  - (c) How will you test the gas evolved ?
  - (d) Write a chemical equation for the above reaction.
  - (e) List two important uses of the above compound.
35. (a) Differentiate between germination and fertilization.  
(b) State in brief the functions of the following parts of the human male reproductive system :  
(i) Scrotum  
(ii) Testes  
(iii) Vas deferens

Continue on next page.....



or

- (a) Draw a neat diagram to show fertilization in a flower and label on it the following parts :  
 (i) Stigma  
 (ii) Pollen tube  
 (iii) Ovary  
 State the function of pollen tube.
- (b) List in tabular form any two differences between a male gamete and a female gamete.

36. (a) For the combination of resistors shown in the following figure, find the equivalent resistance between  $M$  and  $N$ .

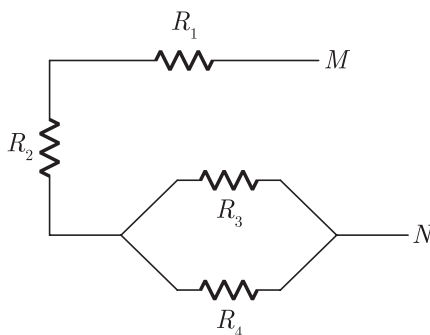

- (b) State Joule’s law of heating.  
 (c) Why we need a 5 A fuse for an electric iron which consumes 1 kW power at 220 V?  
 (d) Why is it impracticable to connect an electric bulb and an electric heater in series?

## SECTION-E

Question no. 37 to 39 are case-based/data -based questions with 2 to 3 short sub-parts. Internal choice is provided in one of these sub-parts.

37. Sample of four metals P, Q, R and S were taken and added to the following solution one by one. The results obtained have been tabulated as follows.

Metal	FeSO <sub>4</sub>	CuSO <sub>4</sub>	ZnSO <sub>4</sub>	AgNO <sub>3</sub>
P	No reaction	Displacement	.....	.....
Q	Displacement		No reaction	Displacement
R	No reaction	No reaction	No reaction	
S	No reaction	No reaction	No reaction	No reaction

- (i) Which is the most reactive metal ?  
 (ii) What would you observe if Q is added to a solution of CuSO<sub>4</sub>. Also, what is the colour change when Q is added to FeSO<sub>4</sub>.

or

What do you mean by displacement reaction ?

Continue on next page.....

38. Question numbers i - iv are based on the table given below. Study the table and answer the following questions.

**Table-A**

S. No.	Generation	Phenotypic ratio
1.	F <sub>1</sub> generation	23 pairs
2.	F <sub>2</sub> generation	22 pairs

- (i) State the law of dominance.  
 (ii) What is the dominant allele?  
 (iii) Define the term phenotype.

**or**

- (iv) What is the meaning of genotype ?

39. A concave mirror forms image of an object thrice in its size on a screen. Magnification of a mirror gives information about the size of the image relative to the object. It is defined as the ratio of size of image to the size of object. It is represented by  $m$ .

$$m = \frac{\text{Size of image}}{\text{Size of object}}$$

Sign of magnification by mirror gives the information about the nature of the image produce by it.

- (i) Describe the nature of image formed.  
 (ii) If the object  $x$  distance from the pole of mirror, then find image distance from the pole.  
 (iii) If the radius of curvature of mirror is R, then write the relation between object distance, image distance and focal length of the mirror.

**or**

- (iv) Give one use of concave mirror.

□□□□□□

**DOWNLOAD INDIA'S BEST STUDY MOBILE APP**

- 30 Sample Paper with Solutions
- Chapterwise Question Bank of All Subject
- Previous 15 Years Solved Papers
- NCERT Solutions
- Case Study Questions with full Solutions
- **Word File of Material for Teachers**

**Search by NODIA on Play Store to Download App**

Add 89056 29969 in Your Class Whatsapp Group to Get Link